



# CONTOUR PEDESTRIAN BRIDGE

\* ALL DIMENSIONS, CONFIGURATIONS, AND MEMBERS SHOWN ARE STANDARD AND MAY VARY. CUSTOM OPTIONS ARE AVAILABLE.



2880 MELLONVILLE AVE, SANFORD, FL 32773

800/256-8857 407/323-0190

THE INFORMATION CONTAINED IN THIS DRAWING IS THE SOLE PROPERTY OF GATOR DOCK & MARINE, LLC. ANY REPRODUCTION IN PART OR AS A WHOLE WITHOUT THE WRITTEN PERMISSION OF GATOR DOCK & MARINE, LLC IS PROHIBITED.

## RECORD OF REVISIONS

No.	DATE	DESCRIPTION

PROJECT NAME:

CUSTOMER NAME:

CUSTOMER ADDRESS:

PROJECT LOCATION:

CMI ORDER NO.:

CUSTOMER PO NO.:

NAME	DATE

DRAWN BY:

CHECKED BY:

DRAWING NO.:

Physical properties are defined by ASTM testing standards, The Aluminum Association Design Manual, The Naval Facilities Design Manual DM 7.2, The US Army Corps of Engineers General Design Guide: PVC Sheet Pile and/or standard engineering practice. The values shown are nominal and may vary. The information found in this document is believed to be true and accurate. No warranties of any kind are made as to the suitability of any CMI product for particular applications or the results obtained there from. ShoreGuard, C-Loc, TimberGuard, GeoGuard, Dura Dock, Shore-All, and Gator Gates are registered trademarks of Crane Materials International. ArmorWare, Ultra Composite, GatorDocks, GatorBridge and CMI Waterfront Solutions are trademarks of Crane Materials International. United States and International Patent numbers: 5,145,297; 5,881,508; 6,000,883; 6,033,155; 6,053,666; D420,154; 4,674,921; 4,690,588; 5,292,208; 6,575,667; 7,059,807; 7,056,066; 7,025,539; 7,393,482; 1,245,061. Other patents pending. © 2010 Crane Materials International. All Rights Reserved.

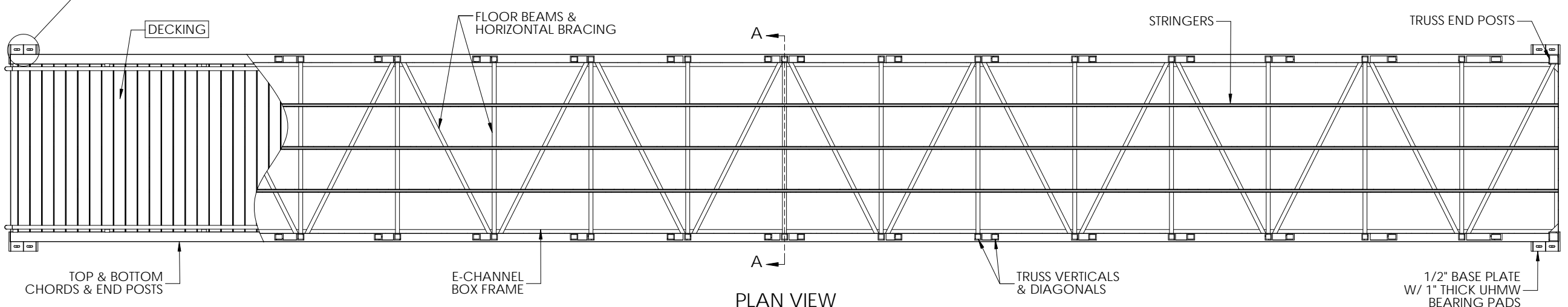
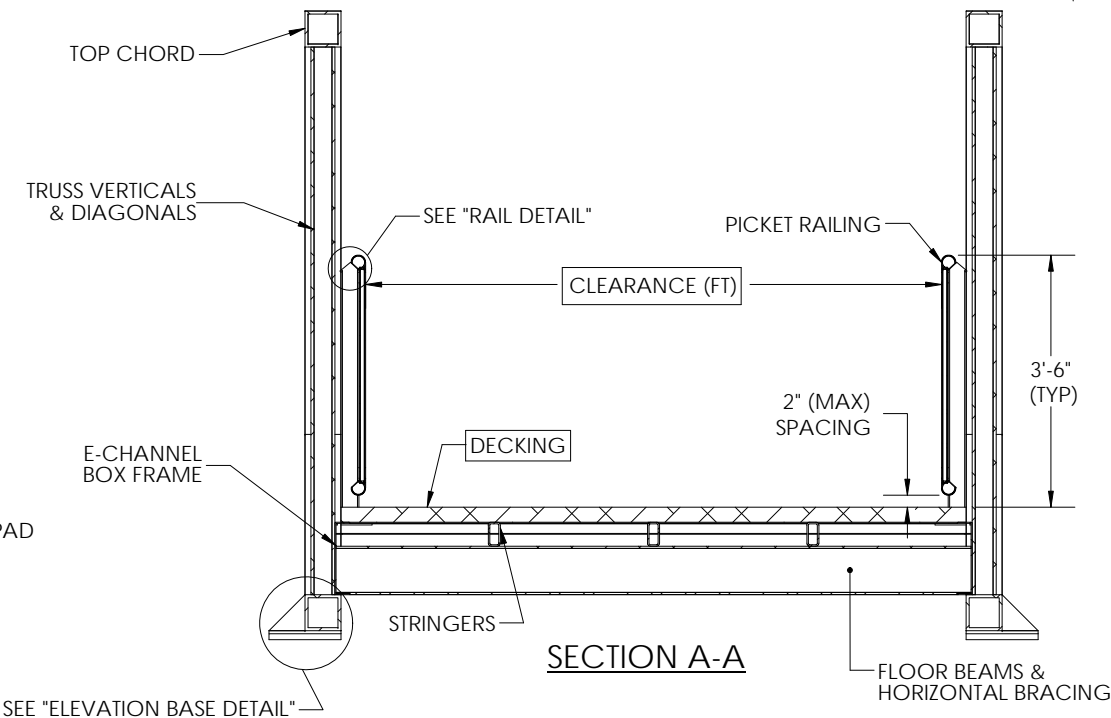
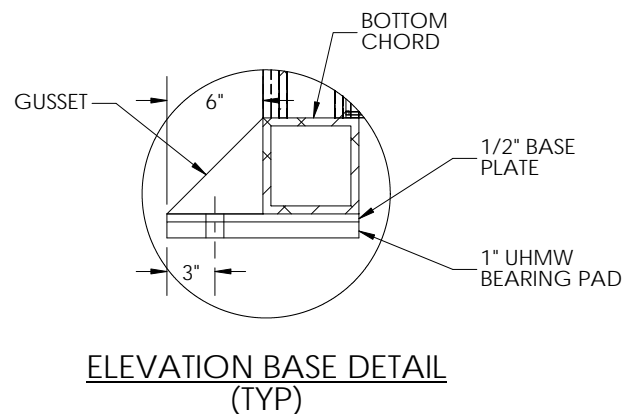
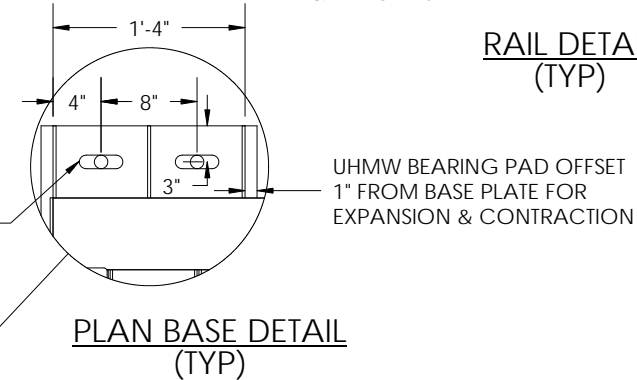
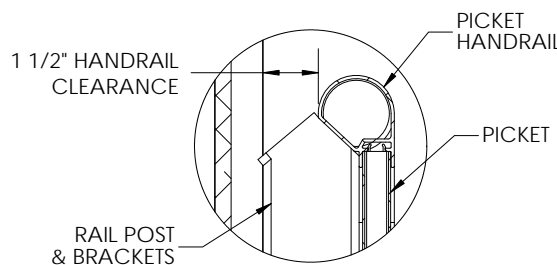
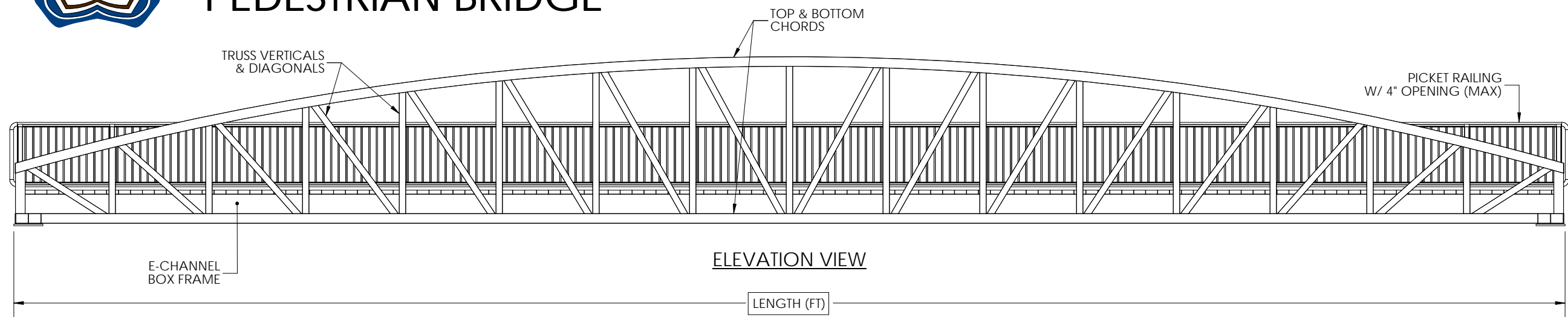

Authorized By: